

**RICOH NC305**

**EDITOR**

---

# 1. SPECIFICATIONS

Maximum Original Size:	A3/LDG
Error Tolerance:	+2.5 mm
Functions:	Delete Area Mode Save Area Mode Black in Area Mode Color in Area Mode Highlight Color Mode Size Magnification Mode
Dimensions: (W x D x H)	528 mm x 468 mm x 54 mm (20.8" x 18.5" x 2.2")
Weight:	Approximately 2.6 kg (5.8 lb) (including stylus and cable)
Power Source:	5 V 0.25 A (from copier)

---

## 2. ELECTRICAL COMPONENT LAYOUT

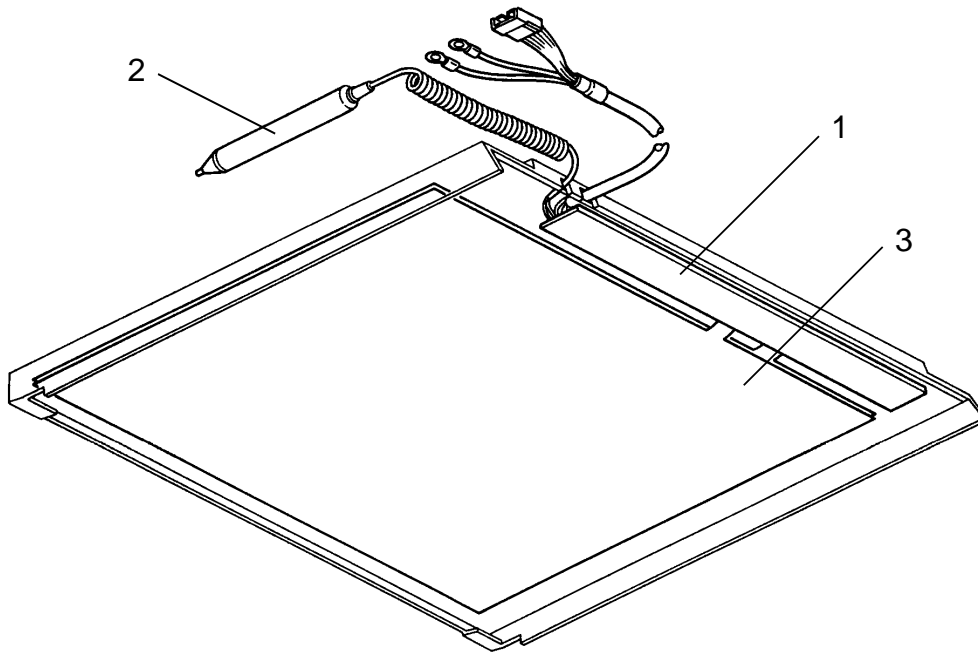

1. Main PCB

2. Stylus

3. Positioning Sheet

---

### 3. ELECTRICAL COMPONENT DESCRIPTIONS

---

**PCBs**

---

Main	Controls the Editor and drives the positioning sheet
------	--

---

**Others**

---

Positing	Detects the stylus position
----------	-----------------------------

---

Stylus	Initializes detection of the position
--------	---------------------------------------

---

## 4. BASIC OPERATION

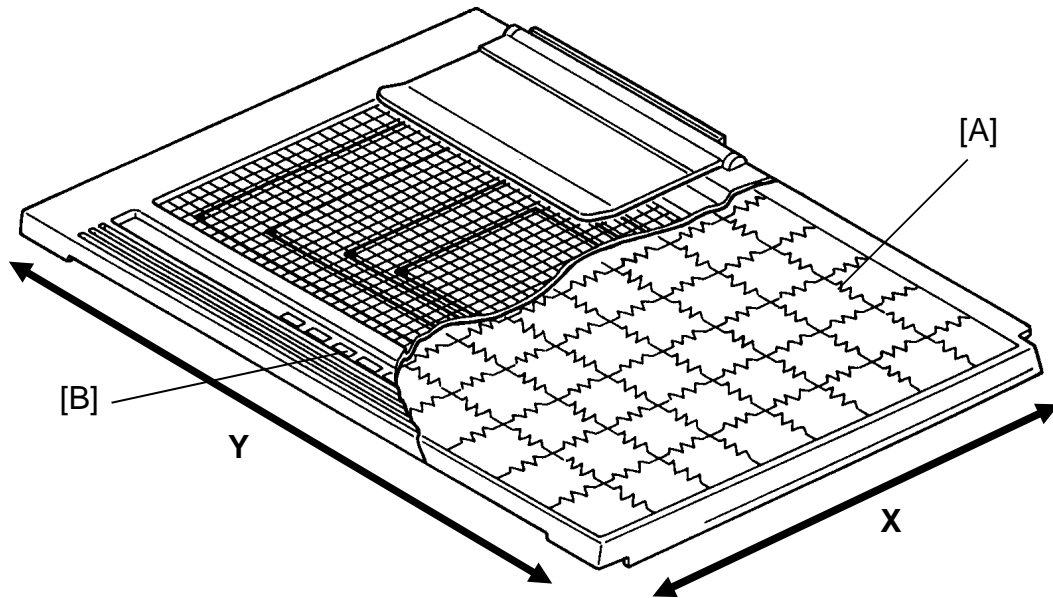

There are resistors [A] (carbon sheets) in the positioning sheet aligned in the X and Y directions. When part of the positioning sheet is pressed with the stylus pen, voltage corresponding to the combination of the resistors is detected.

The detected data is transmitted to the copier as the coordinate position. This detection method also applies to the mode selection pads [B].

## 5. DETECTING METHOD

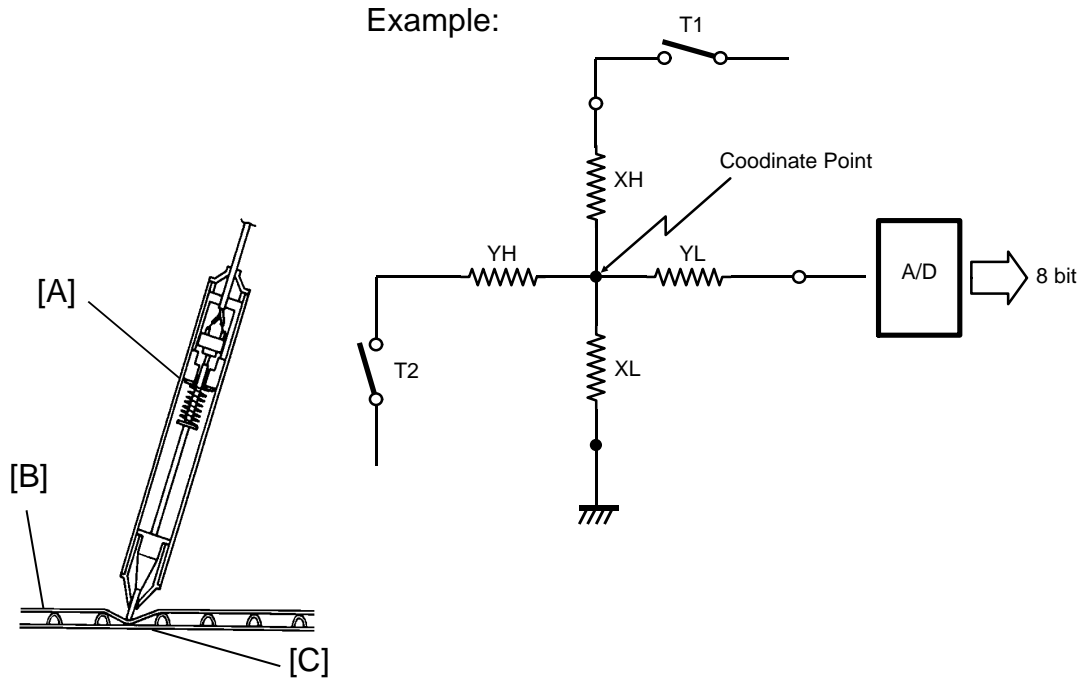

The positioning sheets consists of two carbon sheets for X and Y direction, and insulator dots located in-between the two carbon sheets.

When the positioning sheet is pressed with the stylus pen [A], the switch in the stylus pen turns on and starts the detection of the coordinate point. Also, the upper carbon sheet [B] contacts the lower carbon sheet [C] at the coordinate point. Therefore, the voltage corresponding to the coordinate point is sent to the A/D converter.

### Coordinate Point in X Direction:

The voltage of the coordinate point in the X direction is sent to the A/D converter through the Y line as the switching transistor T1 is turned ON and the voltage is applied to the X line. At this time, the switching transistor T2 should be OFF.

### Coordinate Point in Y Direction:

By changing the ON/OFF position of the switching transistors T1 and T2, the voltage of the coordinate point in the Y direction is sent to the A/D converter through the X line.

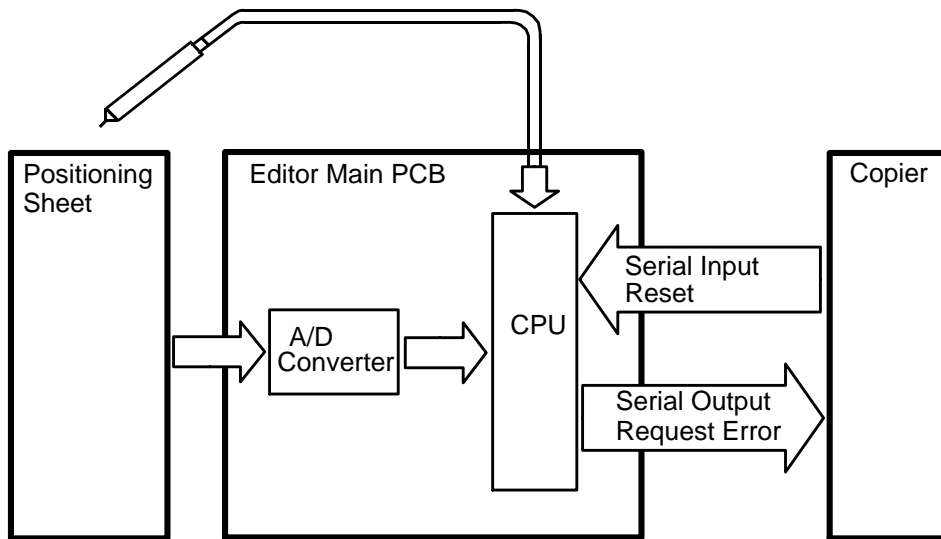

The copier supplies +5 volts to the editor. The signals between the editor and the copier are as follows:

CN No.	Signal	Name Function
1	GND	—
2	Serial Input: TXD (Copier to Editor)	Status signal of copier
3	GND	—
4	Serial Output: RXD (Editor to Copier)	Coordinate data and mode selection data from editor
5	Request (Editor to Copier)	Request to receive data (Serial Input Signal) from copier
6	Error (Editor to Copier)	Request to receive data (Serial Input Signal) again from copier when Serial Input Signal is in error condition
7	Reset (Copier to Editor)	Resets the editor
8	Editor Connection	Connects to GND on Editor board
9 / 10	+5v	Source voltage

---

## **6. ERROR DETECTION**

### **6.1 INITIAL ERROR**

Short circuit and open circuit conditions of the resistors in the positioning sheet are checked when the power is turned ON. If an error is found and coordinate data input is made with the stylus pen, the buzzer sounds for five seconds.

The coordinate position at that time is not transmitted to the copier.

### **6.2 PARITY ERROR (Communication Error)**

When data transmitted from the editor or copier has an error, the service call "SC94" is lit on the copier control panel.



---

## 7. INSTALLATION PROCEDURE (for Machine Code: A072)

### 7.1 ACCESSORY CHECK

Check the quantity and condition of the accessories in the box according to the following list:

1. Installation Procedure.....	1
2. New Equipment Condition Report .....	1
(17 and 27 machines)	
3. Envelope for NECR (17 machine only) .....	1
4. Protective Plate .....	2
5. Front Stopper.....	2
6. Rear Stopper .....	2
7. Grounding Screw .....	1
8. Screw - M4 x 6.....	4
9. Truss Screw - M4 x 8.....	2
10. Platen Cover Hinge .....	1
11. Harness Cramp .....	1
12. Tie Wrap .....	1
13. Mounting Bracket .....	1
14. Pan Head Screw – M5 x 8.....	2
15. Tapping Screw – M4 x 12.....	6
16. Pan Head Screw – M4 x 8.....	1
17. Multilingual Decal (16, 25, 26 and 27 machines) .....	1

## 7.2 EDITOR INSTALLATION (on Platen Cover)

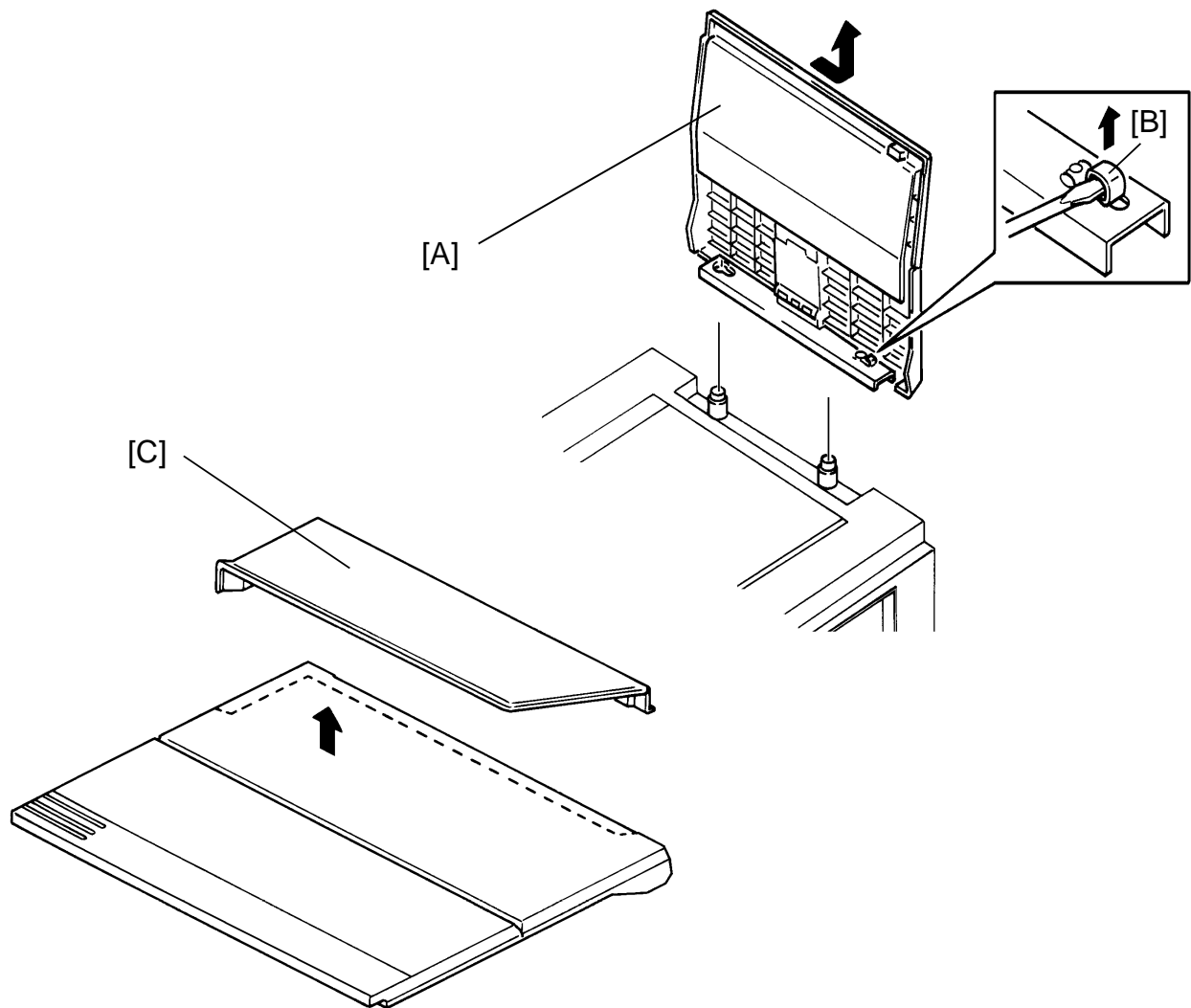

1. Turn off the main switch and unplug the machine.
2. Remove the strips of shipping tape and check the condition of the stylus pen.
3. Remove the platen cover [A] (Use a minus (slotted) screw driver to lift up the leaf spring [B] as shown and slide the platen cover to the right).
4. Remove the original holder [C] from the platen cover.

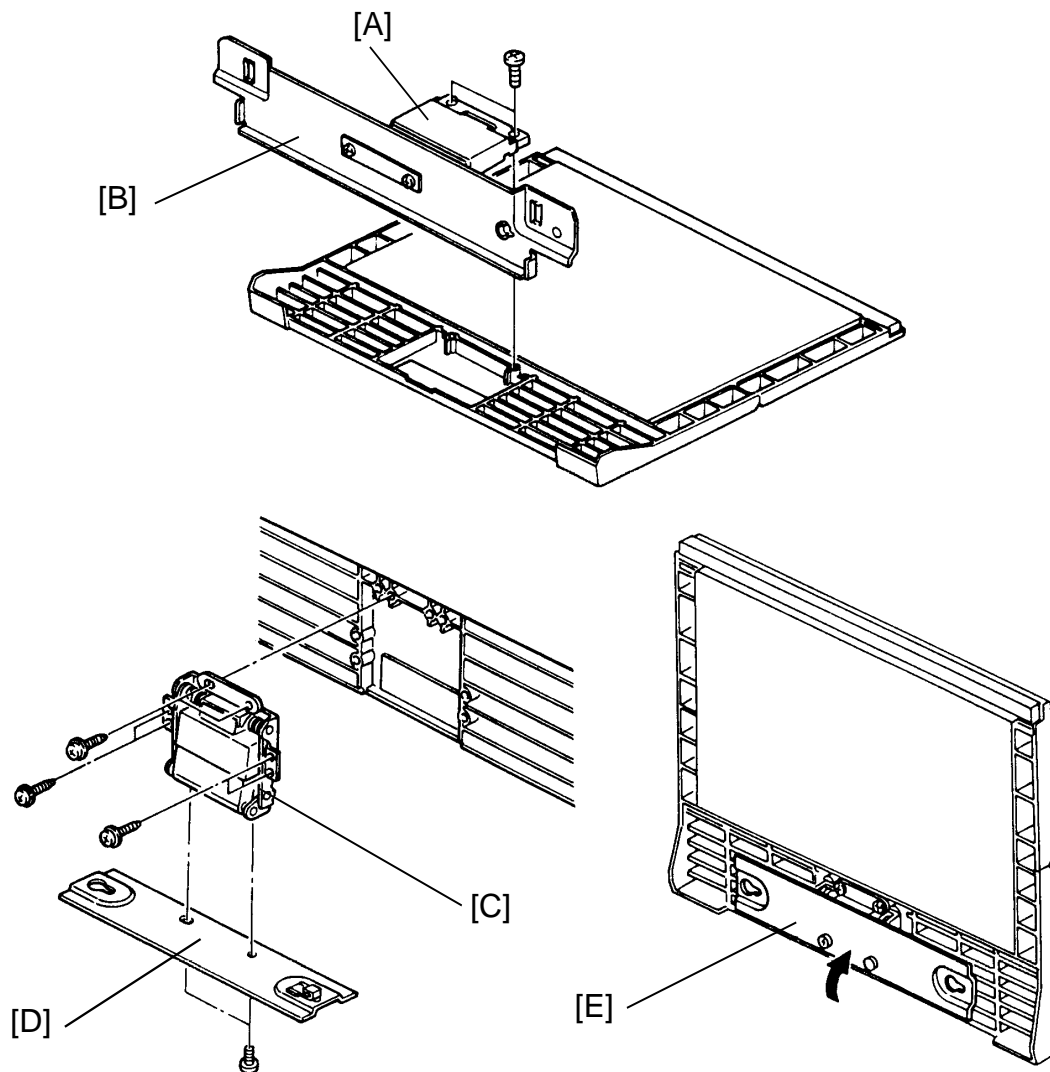

5. Remove the platen cover hinge [A] and the mounting bracket [B] from the platen cover (2 screws).
6. Install the accessory platen hinge [C] (6 screws - M4 x 12) and the mounting bracket [D] (2 screws - M5 x 8).
7. Close the mounting bracket [E] of the platen cover.

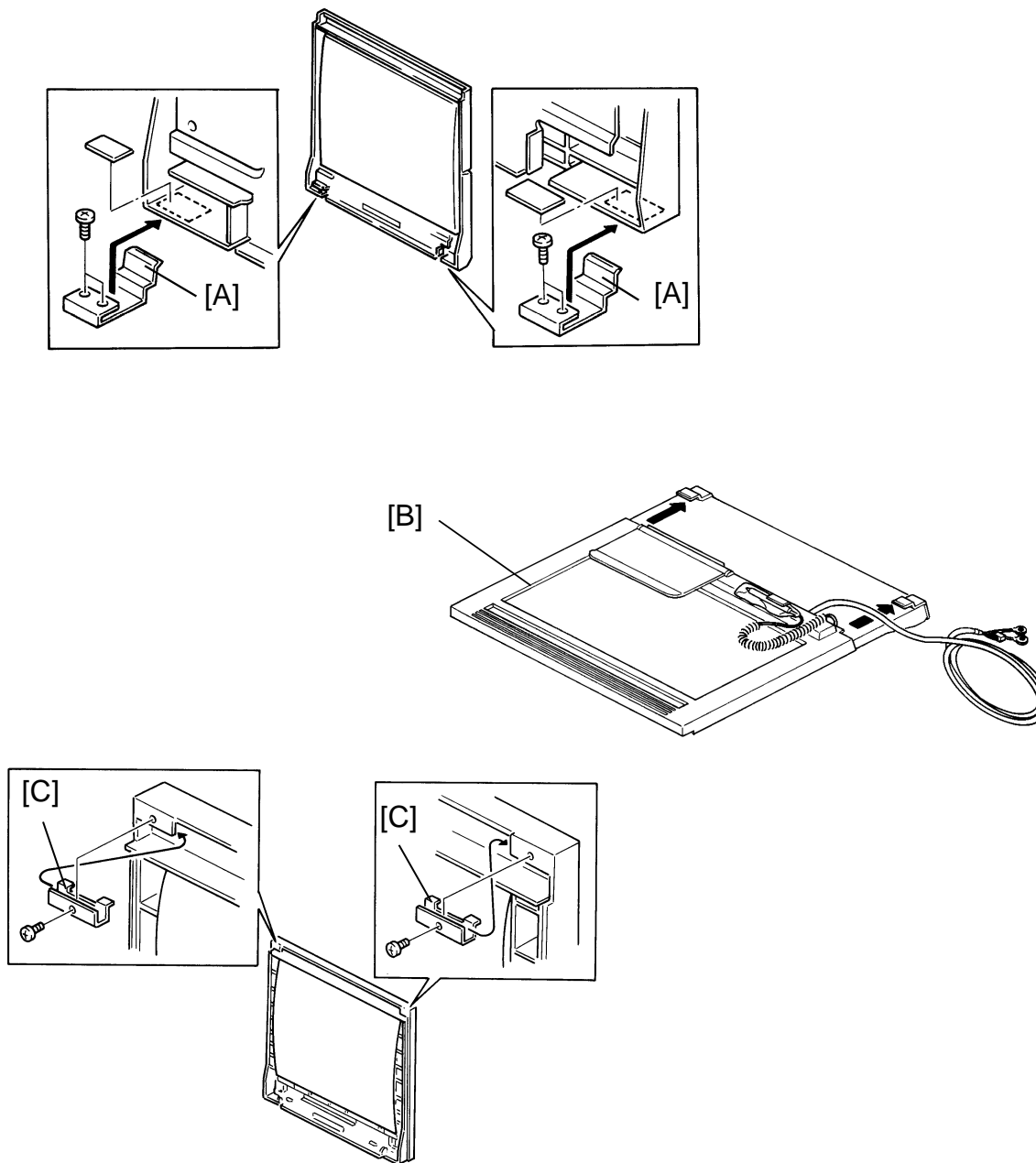

8. Install the rear stoppers [A] to the right and left sides of the platen cover as shown (2 screws each: M4 x 6).
9. Place the editor [B] on the platen cover from the operation side as shown and secure the right and left ends of the editor with the front stoppers [C] (1 screw each: truss screw - M4 x 8)
10. Open the hinge and reinstall the platen cover (with editor board) on the copier.

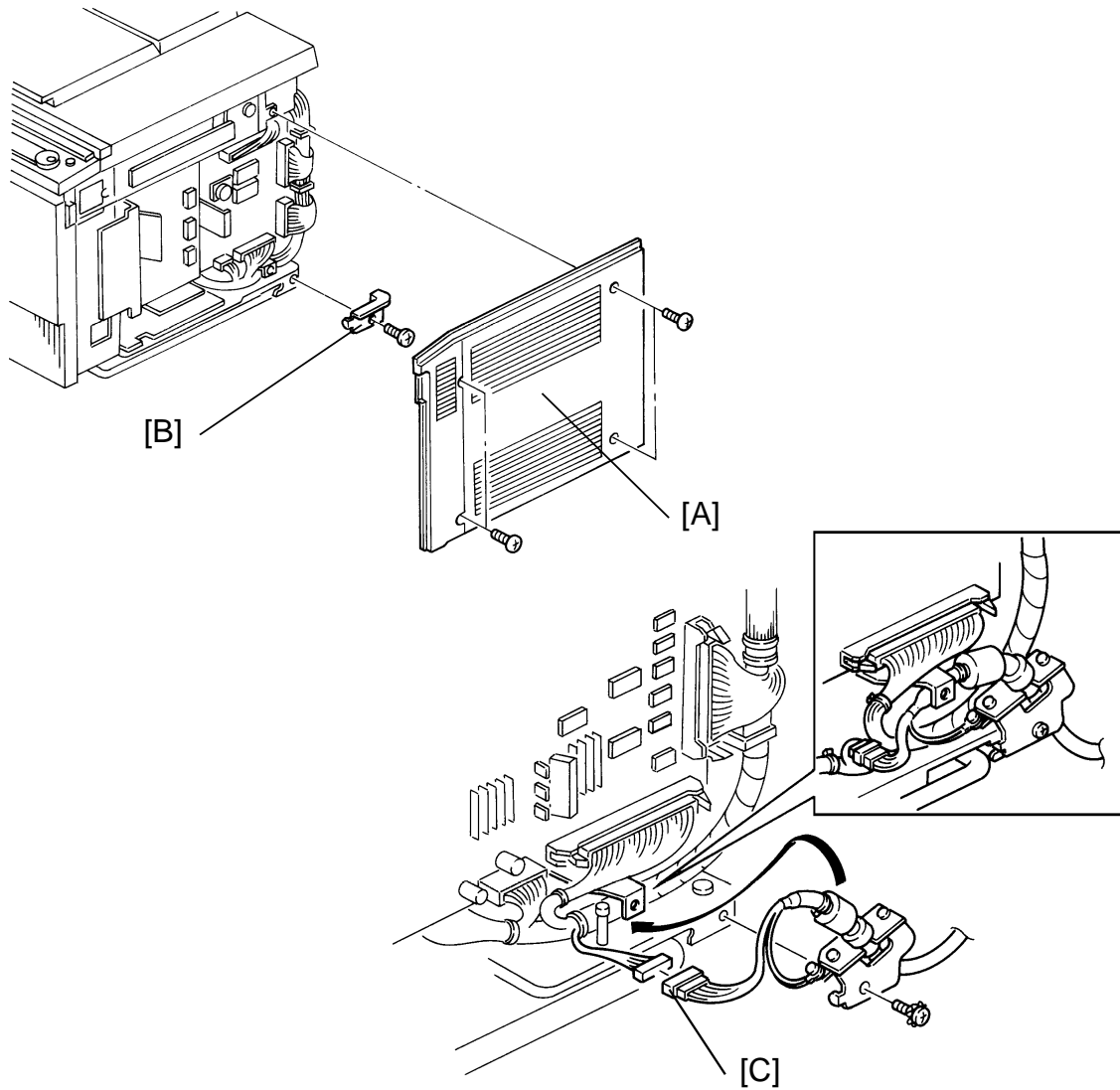

11. Remove the right cover [A] (4 screws).
12. Remove the securing bracket [B] (1 screw).
13. Connect the editor harness [C] (white, 10P) and secure the harness bracket (1 grounding screw).
14. Check the editor operation.

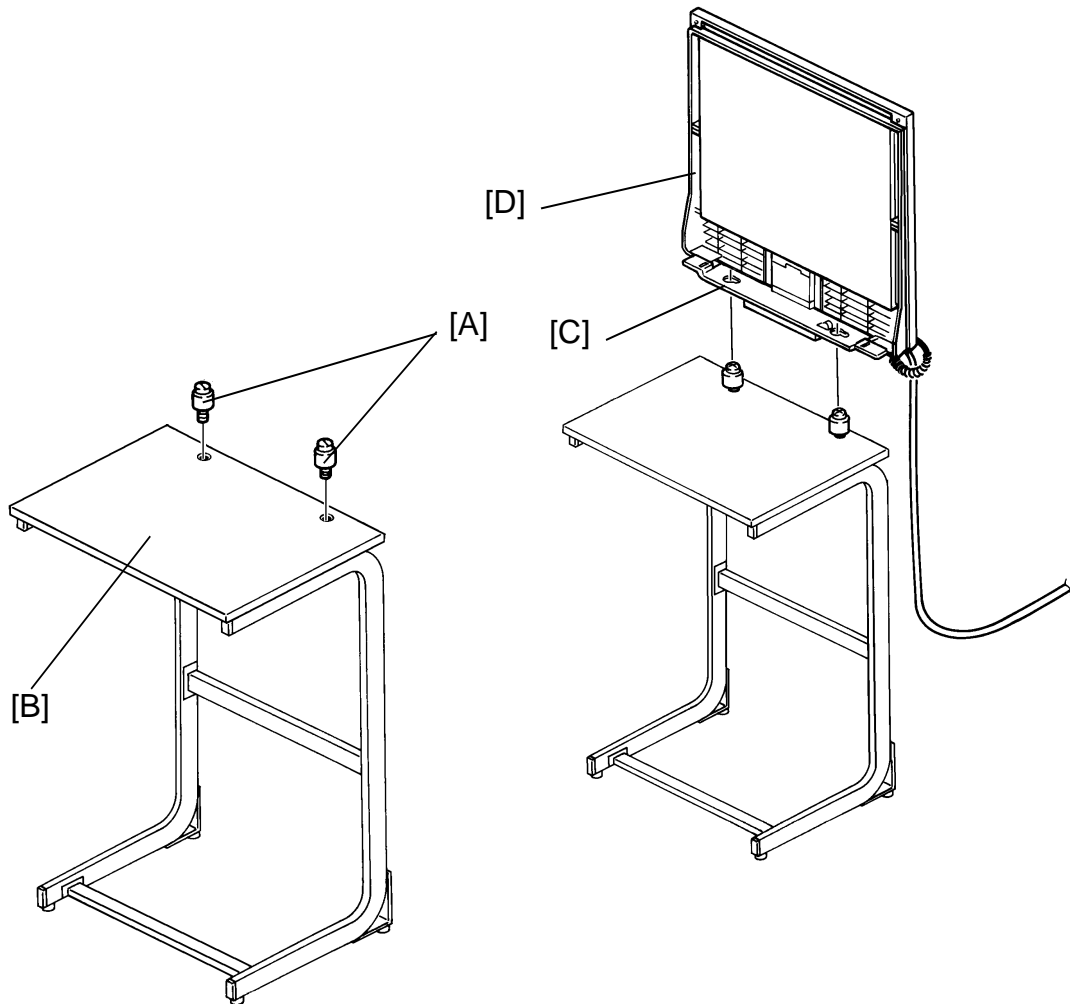

### INSTALLATION PROCEDURE (on Editor Table)

1. Remove the platen cover (2 screws) and set the editor on the platen cover (from the operation side).  
Refer to steps 2 to 9 on previous pages. (Except steps 5 and 6.)  
**NOTE:** When installing the editor on the editor table, do not install the accessory platen cover hinge and the mounting bracket.
2. Reinstall the 2 studs [A], which were removed from the copier on the editor table [B].
3. Open the hinge [C] and install the platen cover (with editor) [D] on the editor table.  
Refer to steps 11 to 14 on previous pages.
4. Check the editor operation.

## 8. REPLACEMENT AND ADJUSTMENT

### 8.1 MAIN PCB REPLACEMENT

**CAUTION:** Do not touch the DIP switch on the main PCB as it is factory preset.

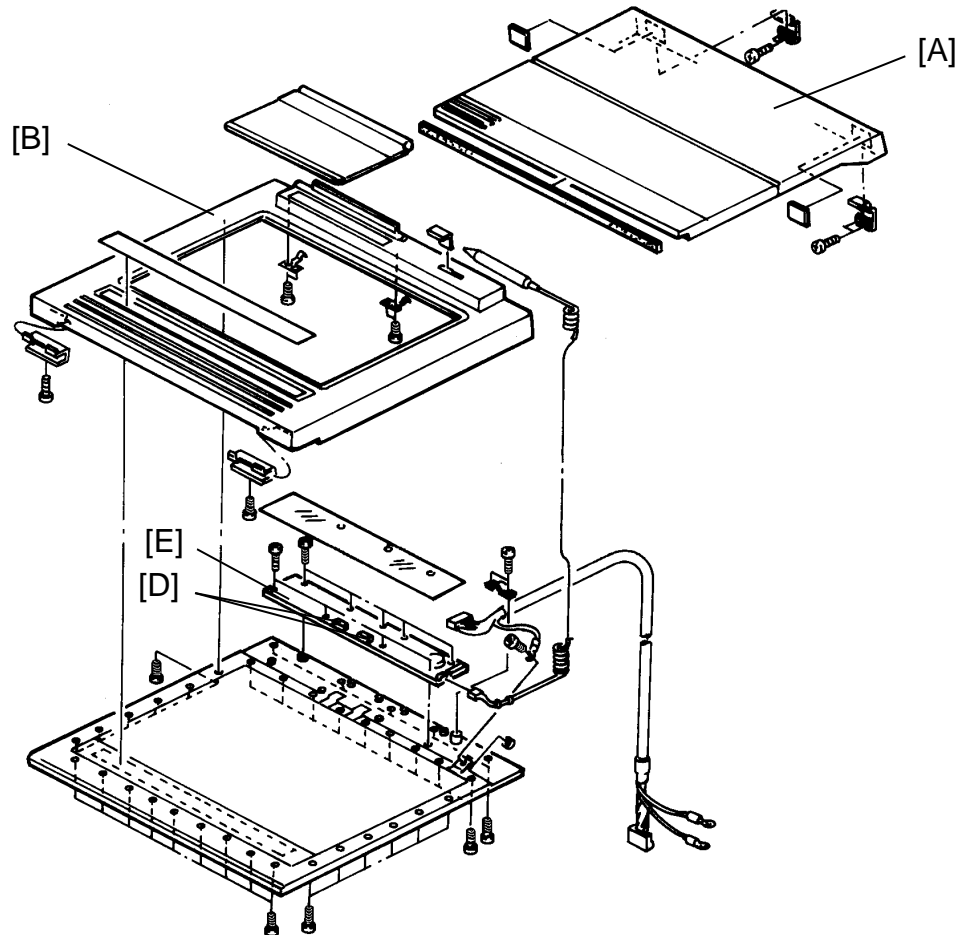

1. Disconnect the editor connectors.
2. Remove the editor from the platen cover [A] (6 screws).
3. Remove the upper cover [B] (35 screws).

**NOTE:** Carefully remove the upper cover as it is held down with double sided tape.

4. Remove the connectors [C].
5. Remove the connector [D] and replace the main PCB [E] (9 screws).